

Project: CPS2 Reverse Engineering: DL-1927
 Author: Loic *WydD* Petit
 Licence: CC-BY

Sheet: /
 File: DL-1927.sch

Title: DL-1927

Size: A4 Date: 2020-05-05
 KiCad E.D.A. eeschema 5.1.7-a382d34a887ubuntu18.04.1

Rev:
 Id: 1/8

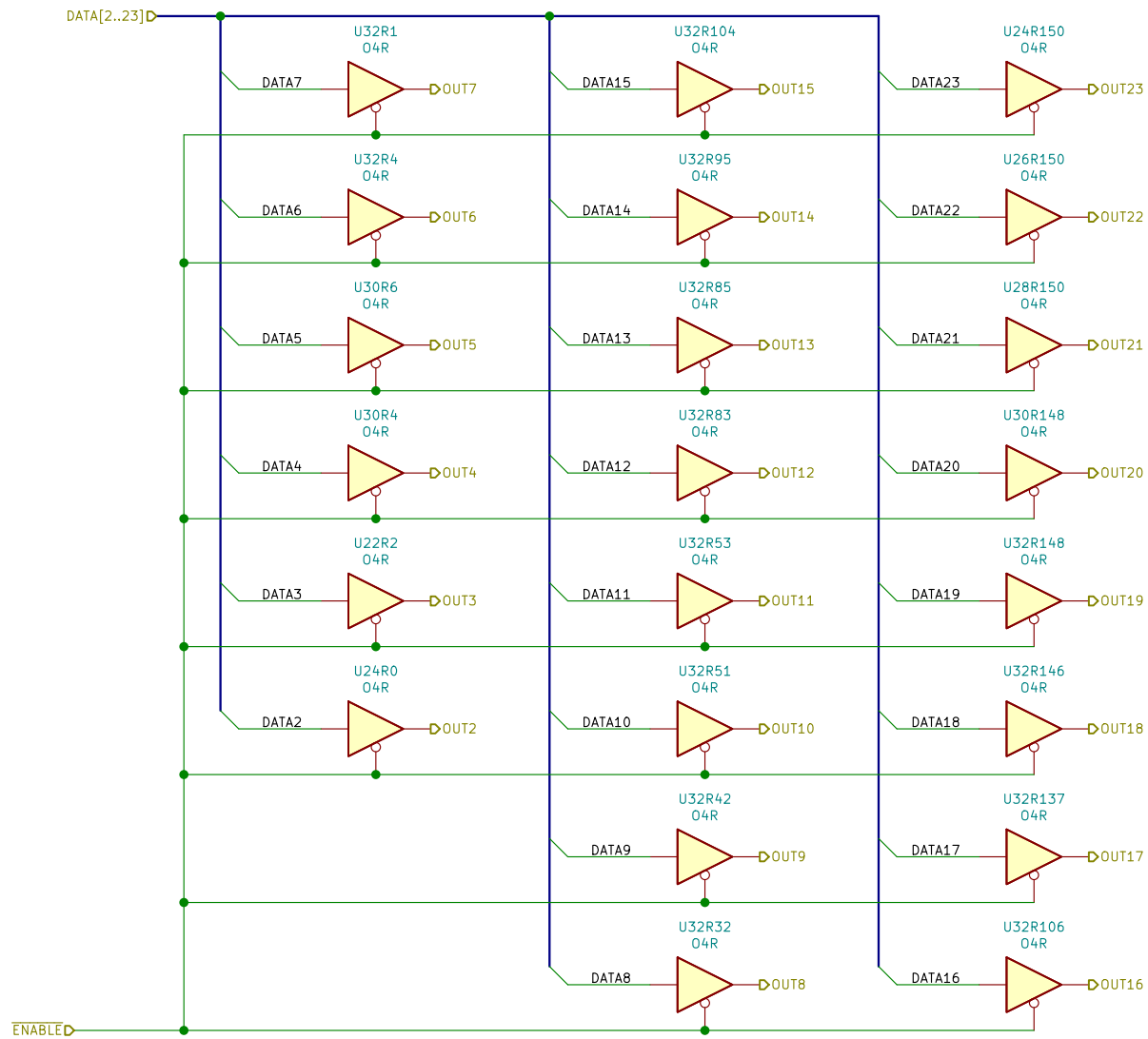

Project: CPS2 Reverse Engineering: DL-1927
 Author: Loic *Wyd* Petit
 Licence: CC-BY

Sheet: /a-out/
 File: a-out.sch

Title:

Size: A4 Date: 2020-05-05
 KiCad E.D.A. eeschema 5.1.7-a382d34a887ubuntu18.04.1

Rev:
 Id: 2/8

DATA[2..23]

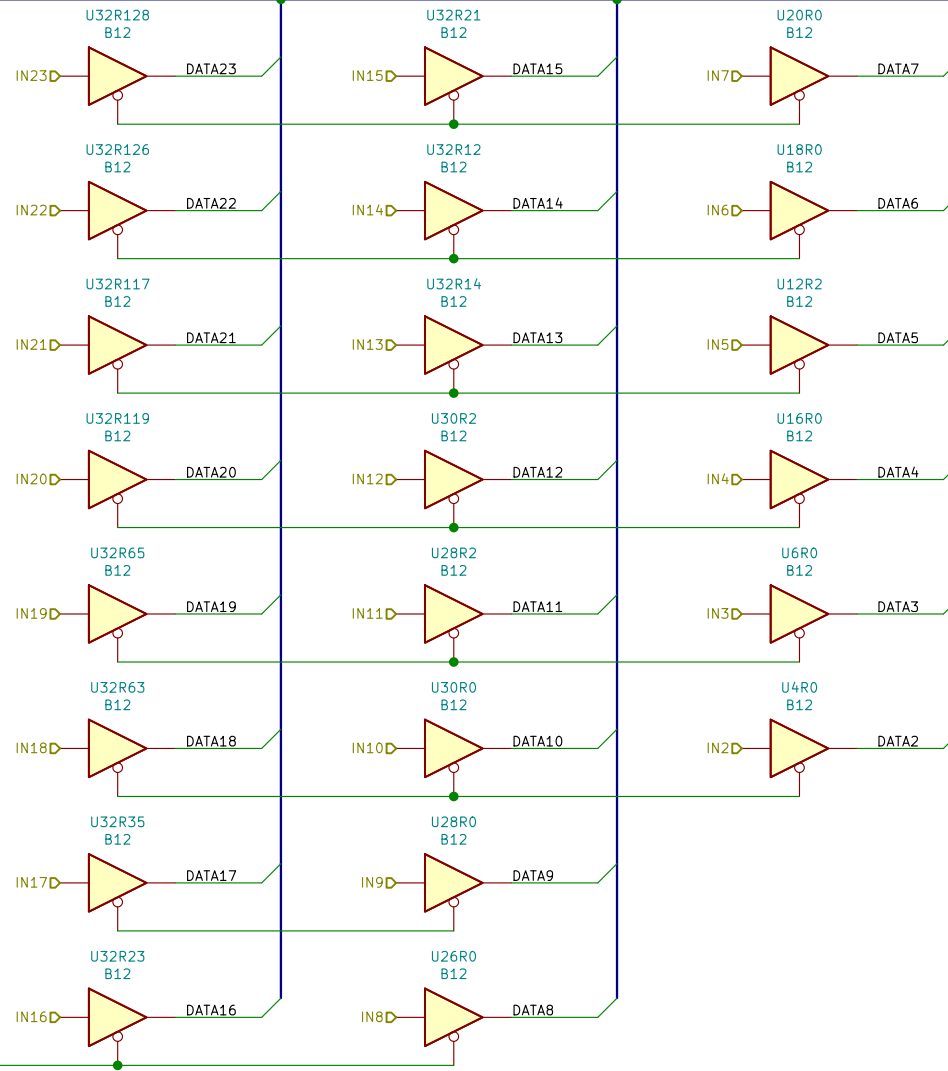

ENABLE

Project: CPS2 Reverse Engineering: DL-1927
Author: Loic *Wyd* Petit
Licence: CC-BY

Sheet: /a01-input/
File: a01-input.sch

Title:

Size: A4
Date: 2020-05-05
KiCad E.D.A. eeschema 5.1.7-a382d34a887ubuntu18.04.1

Rev:
Id: 3/8

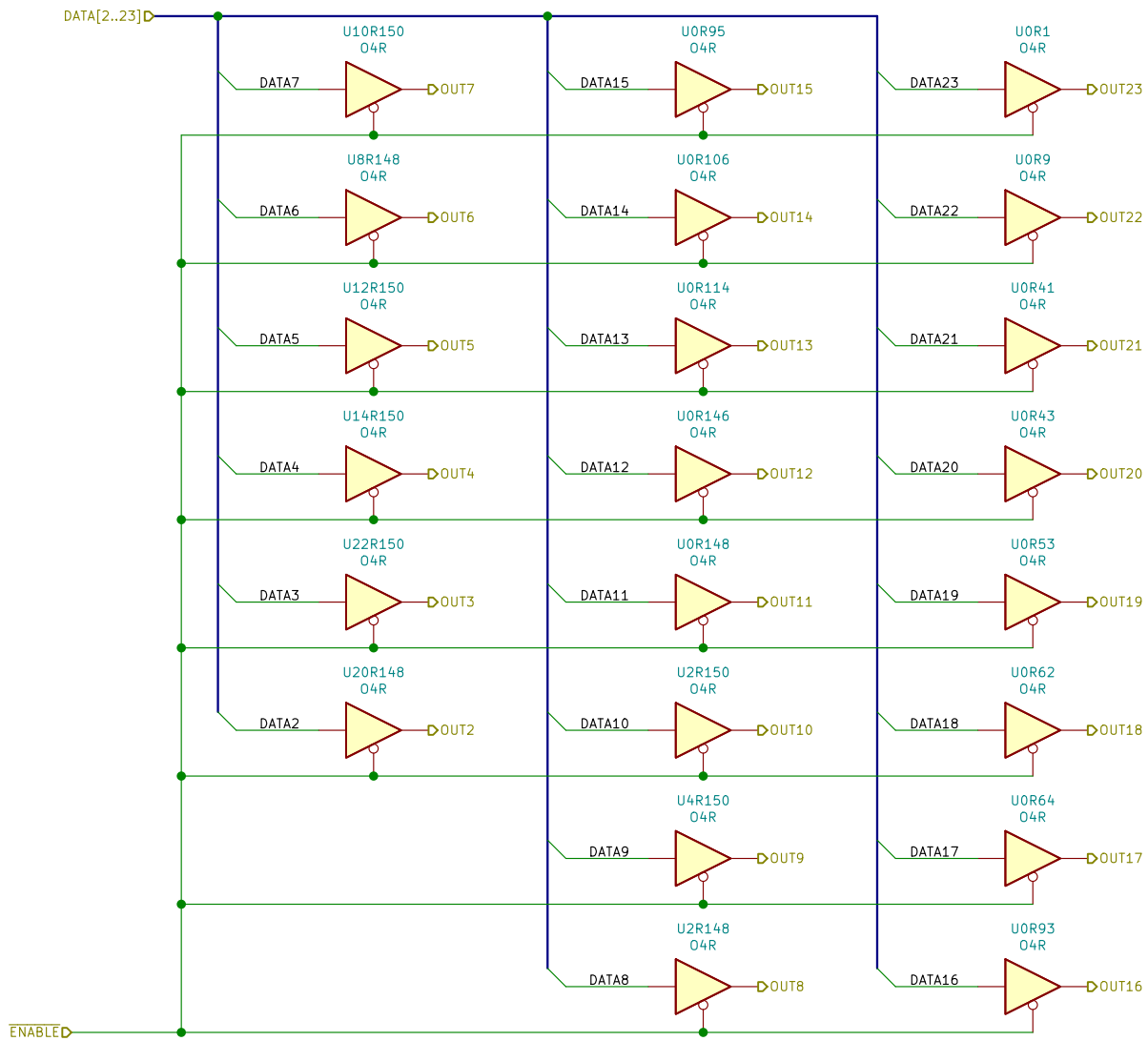

Project: CPS2 Reverse Engineering: DL-1927
 Author: Loic *Wyd* Petit
 Licence: CC-BY

Sheet: /b-out/
 File: b-out.sch

Title:

Size: A4 Date: 2020-05-05
 KiCad E.D.A. eeschema 5.1.7-a382d34a887ubuntu18.04.1

Rev:
 Id: 4/8

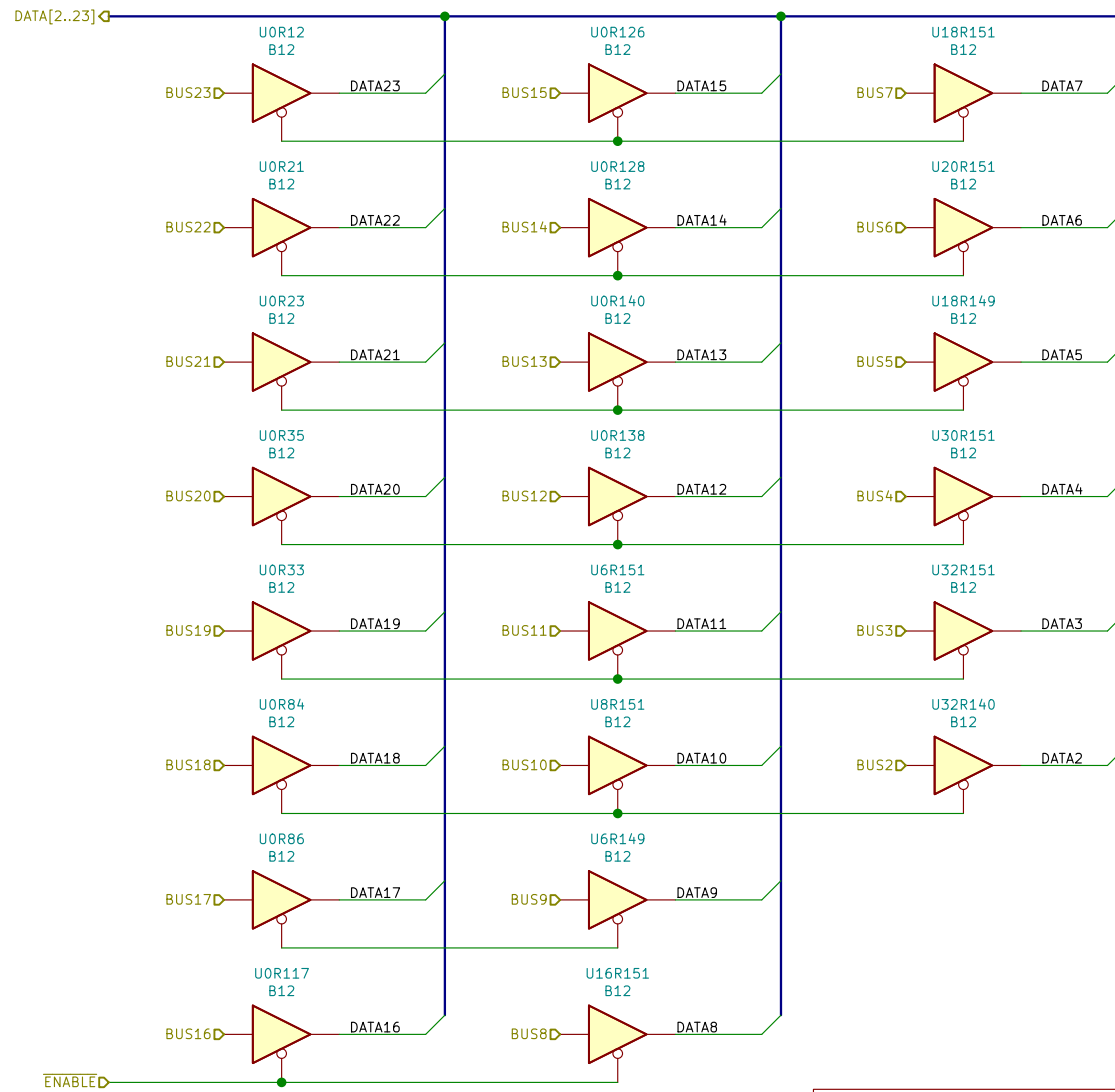

Project: CPS2 Reverse Engineering: DL-1927
 Author: Loic *WydD* Petit
 Licence: CC-BY

Sheet: /bus-input/
 File: bus-input.sch

Title:

Size: A4 Date: 2020-05-05

KiCad E.D.A. eeschema 5.1.7-a382d34a887ubuntu18.04.1

Rev:
 Id: 5/8

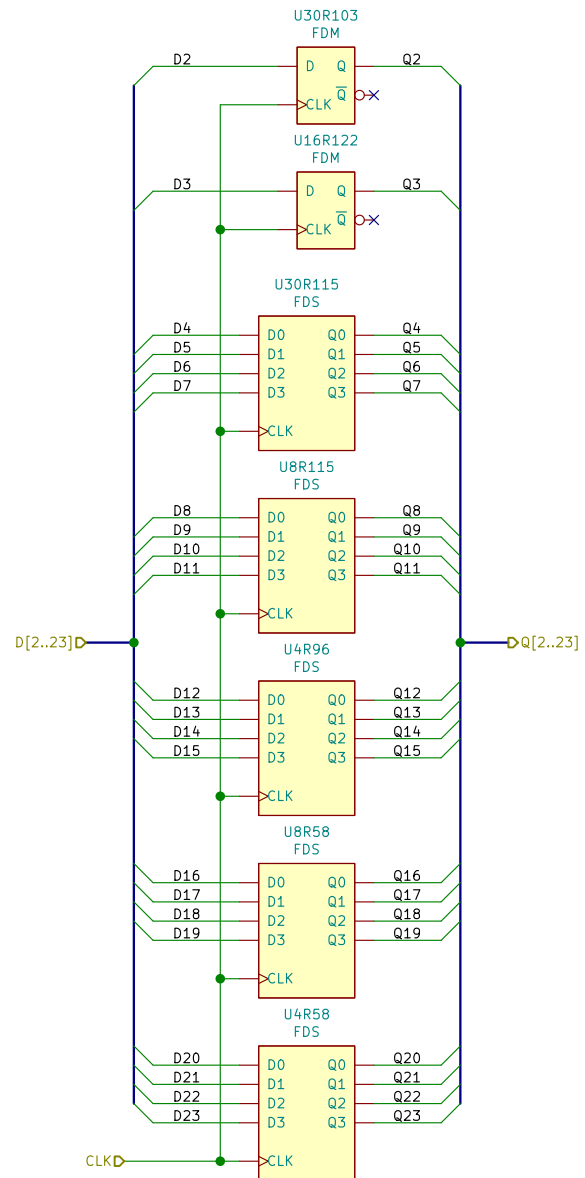

Project: CPS2 Reverse Engineering: DL-1927
 Author: Loic *Wyd* Petit
 Licence: CC-BY

Sheet: /bus-memory/
 File: bus-memory.sch

Title:

Size: A4 Date: 2020-05-05
 KiCad E.D.A. eeschema 5.1.7-a382d34a887ubuntu18.04.1

Rev:
 Id: 6/8

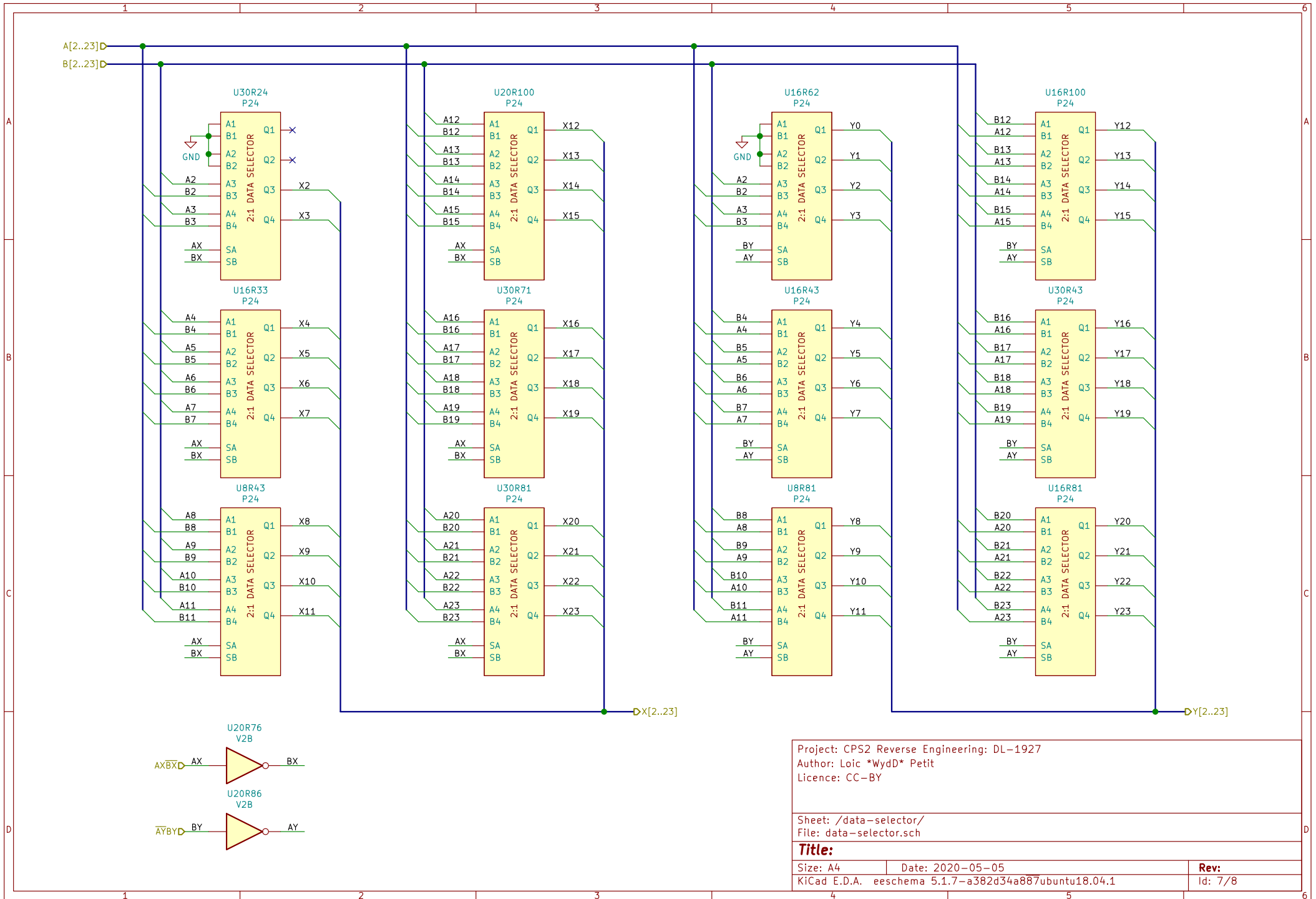

Project: CPS2 Reverse Engineering: DL-1927
 Author: Loic *Wyd* Petit
 Licence: CC-BY

Sheet: /data-selector/
 File: data-selector.sch

Title:

Size: A4 Date: 2020-05-05
 KiCad E.D.A. eeschema 5.1.7-a382d34a887ubuntu18.04.1

Rev:
 Id: 7/8

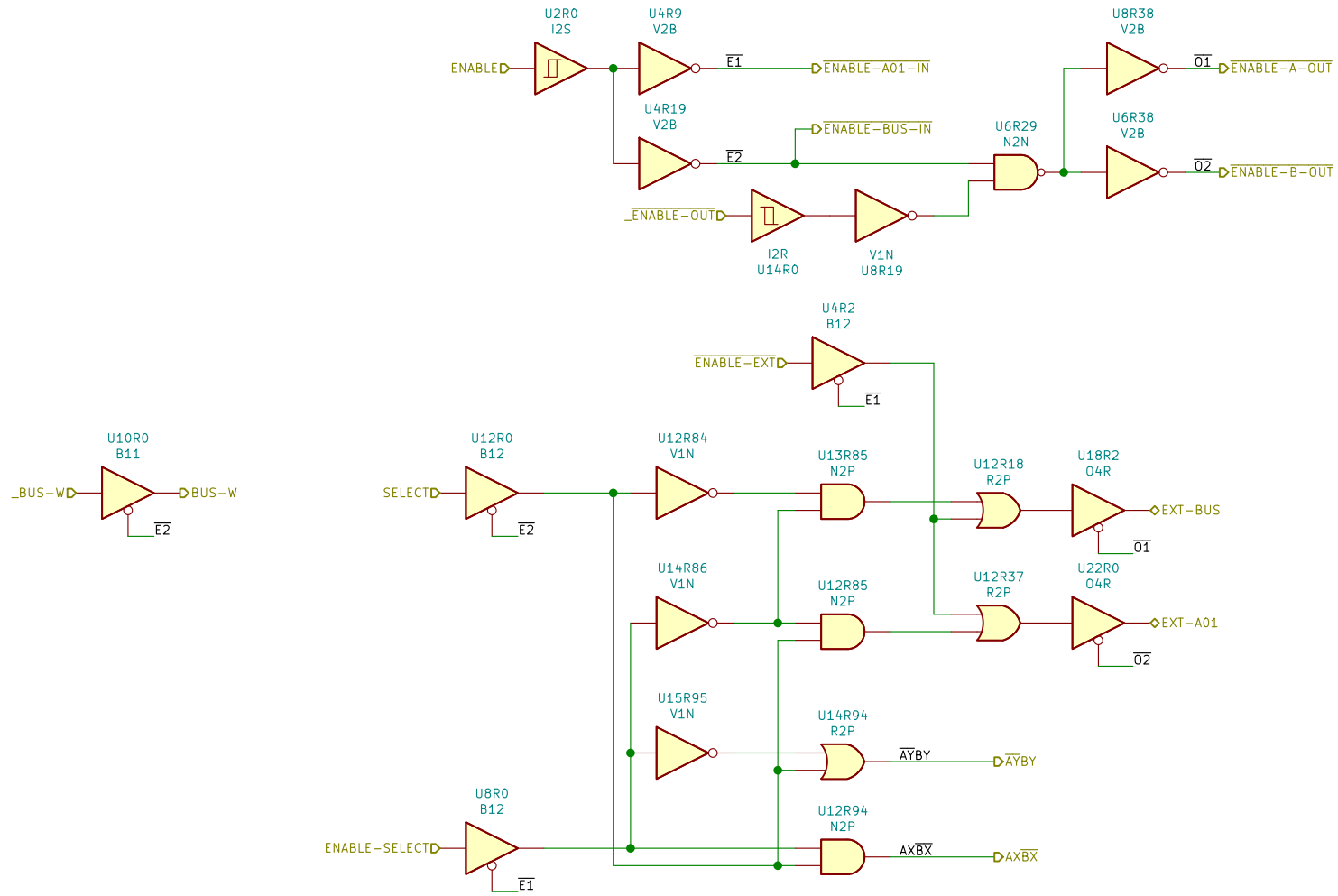

Project: CPS2 Reverse Engineering: DL-1927
 Author: Loic *Wyd* Petit
 Licence: CC-BY

Sheet: /enable/
 File: enable.sch

Title:	
Size: A4	Date: 2020-05-05
KiCad E.D.A. eeschema 5.1.7-a382d34a887ubuntu18.04.1	Rev: Id: 8/8