

CPSA-E is a signal that enables reading control signals coming from the CPSA board. On CPS2, this is bound to GND so all control signals are available.

DEBUG-RANGE enables the output of two unused additional ranges of the address decoder. On CPS2, if the A-board is plugged, this is plugged to GND

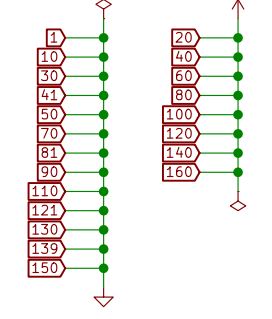

This bus multiplexer is a way to see various inputs after buffers. On CPS2, the output is not enabled so pins are just NC, also S0-S2 are bound to GND

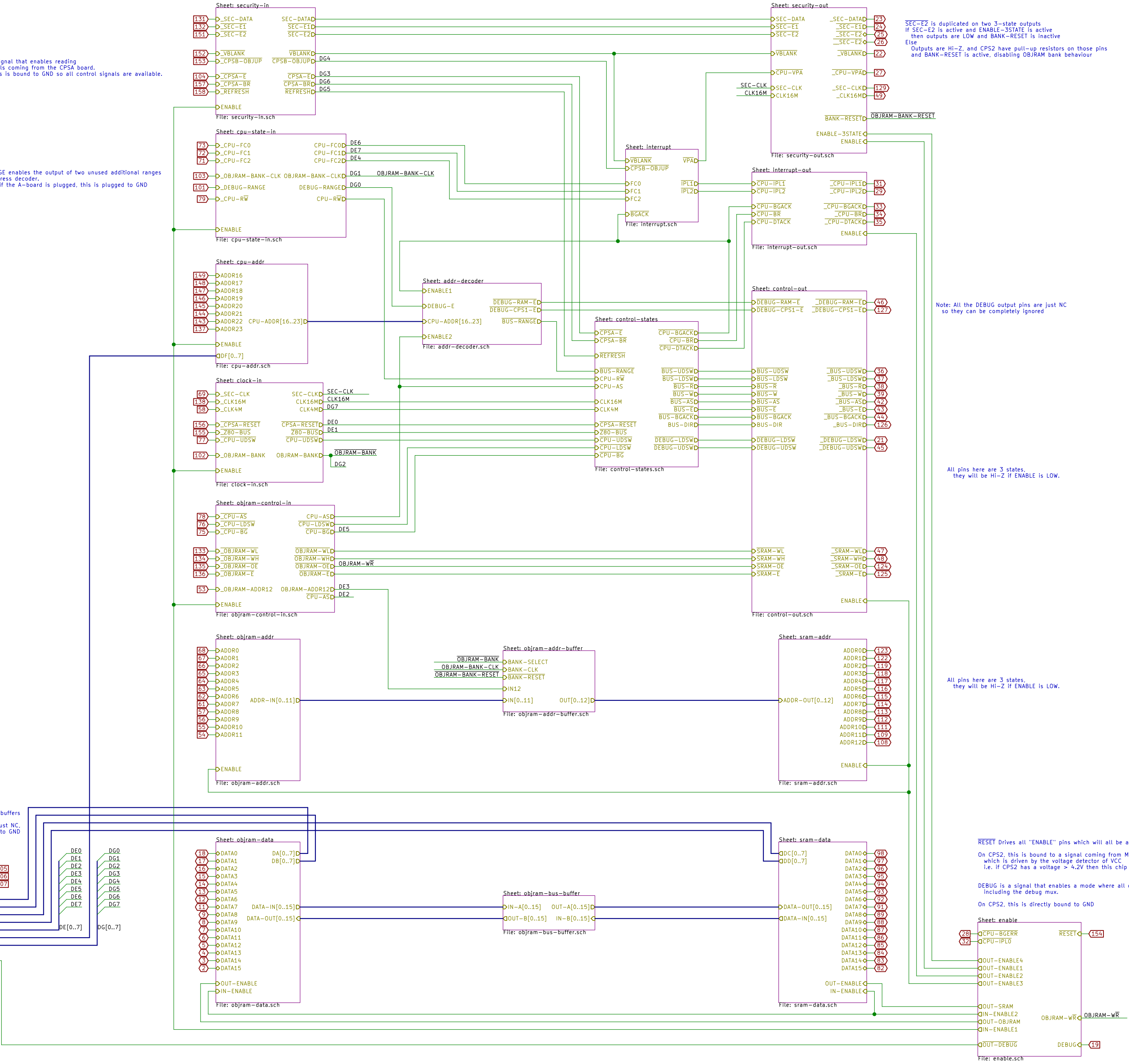
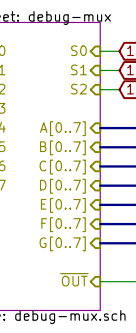

SEC-E2 is duplicated on two 3-state outputs. If SEC-E2 is active and ENABLE-3STATE is active then outputs are LOW and BANK-RESET is inactive. Else outputs are Hi-Z, and CPS2 have pull-up resistors on those pins and BANK-RESET is active, disabling OBJRAM bank behaviour.

Note: All the DEBUG output pins are just NC so they can be completely ignored

All pins here are 3 states, they will be Hi-Z if ENABLE is LOW.

All pins here are 3 states, they will be Hi-Z if ENABLE is LOW.

RESET Drives all "ENABLE" pins which will all be active if RESET is inactive. On CPS2, this is bound to a signal coming from MIF which is driven by the voltage detector of VCC. i.e. if CPS2 has a voltage > 4.2V then this chip will work as intended.

DEBUG is a signal that enables a mode where all outputs are enabled including the debug mux. On CPS2, this is directly bound to GND

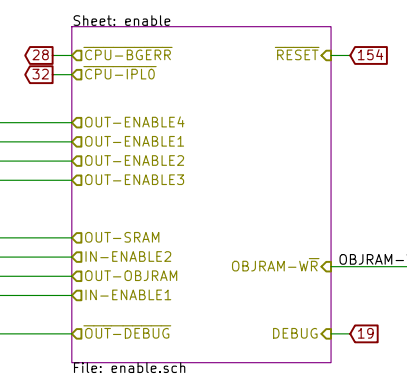

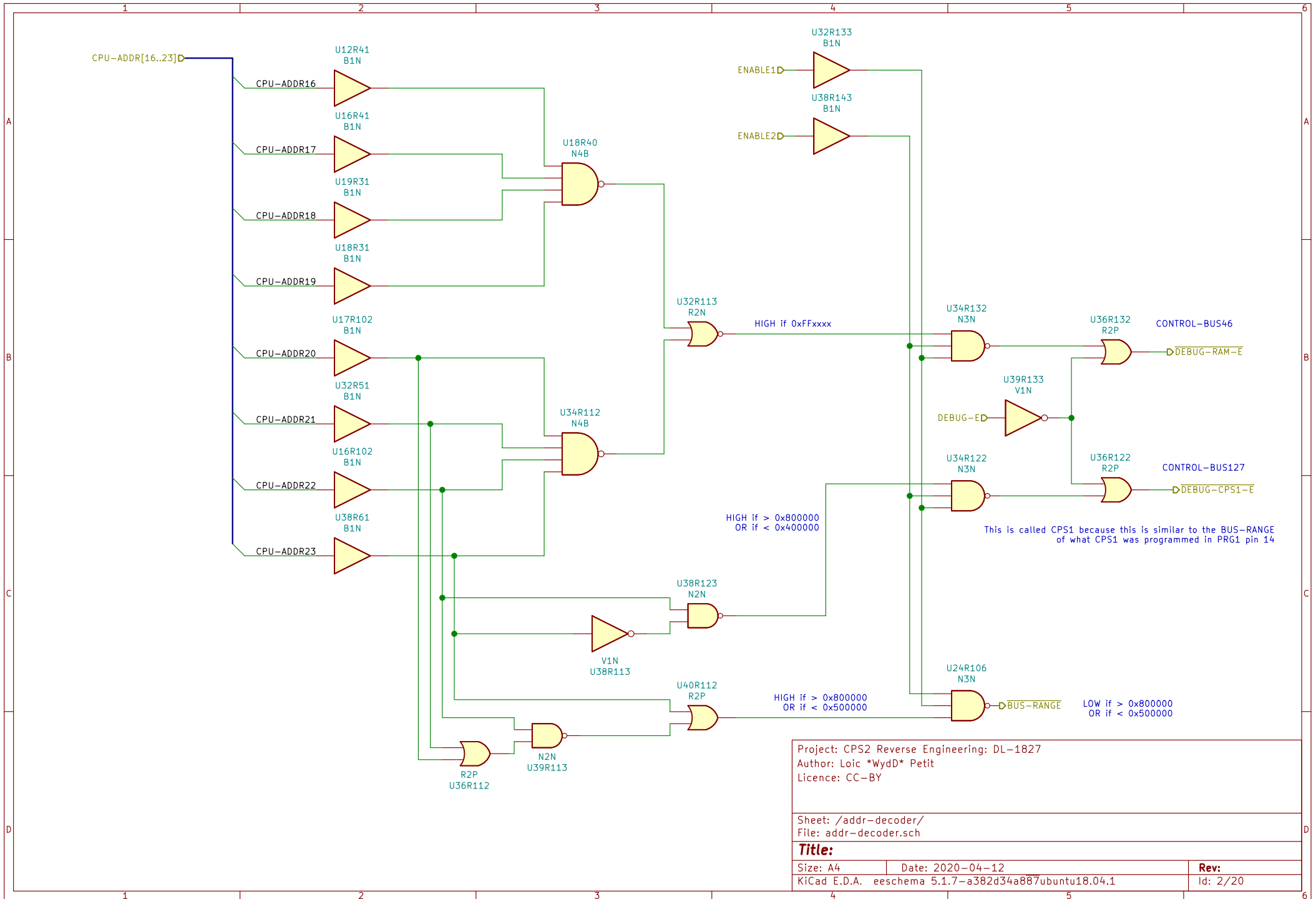

Project: CPS2 Reverse Engineering: DL-1827
 Author: Loic *WydD* Petit
 Licence: CC-BY

Sheet: /addr-decoder/
 File: addr-decoder.sch

Title:

Size: A4 Date: 2020-04-12
 KiCad E.D.A. eeschema 5.1.7-a382d34a887ubuntu18.04.1

Rev:
 Id: 2/20

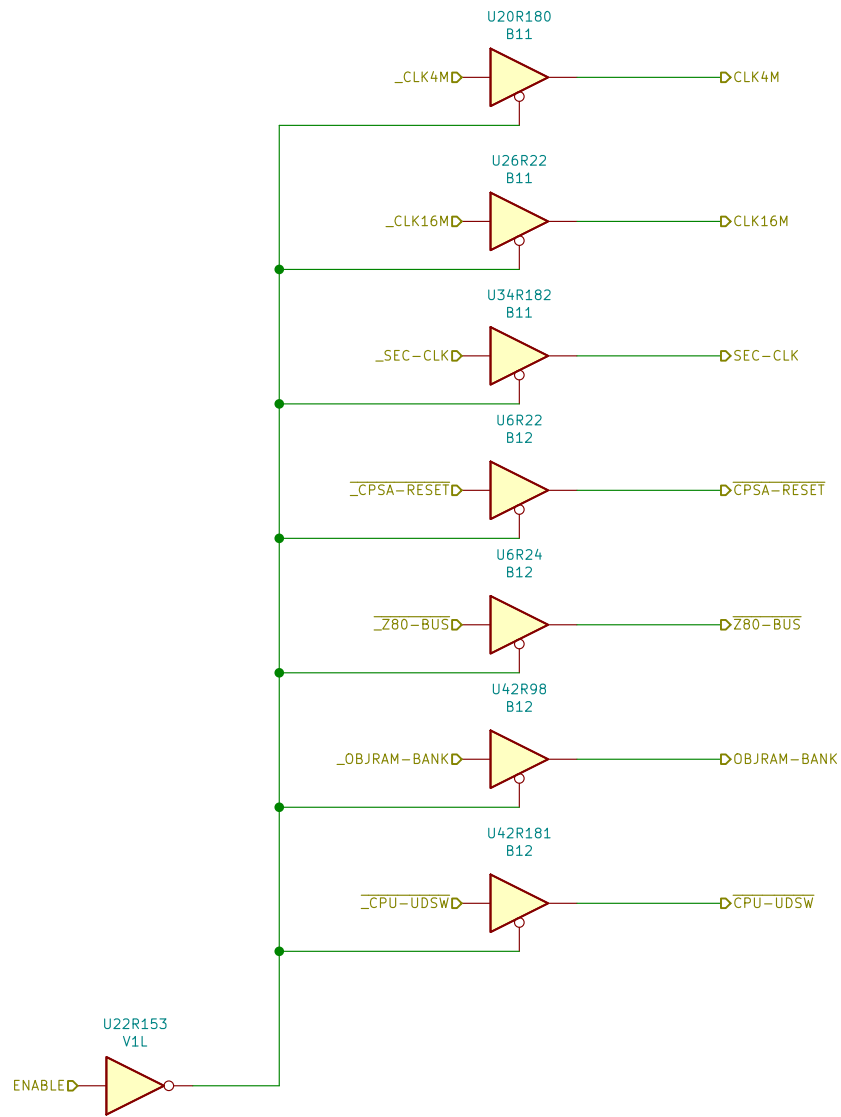

Project: CPS2 Reverse Engineering: DL-1827
 Author: Loic *WydD* Petit
 Licence: CC-BY

Sheet: /clock-in/
 File: clock-in.sch

Title:

Size: A4 Date: 2020-04-12
 KiCad E.D.A. eeschema 5.1.7-a382d34a887ubuntu18.04.1

Rev:
 Id: 3/20

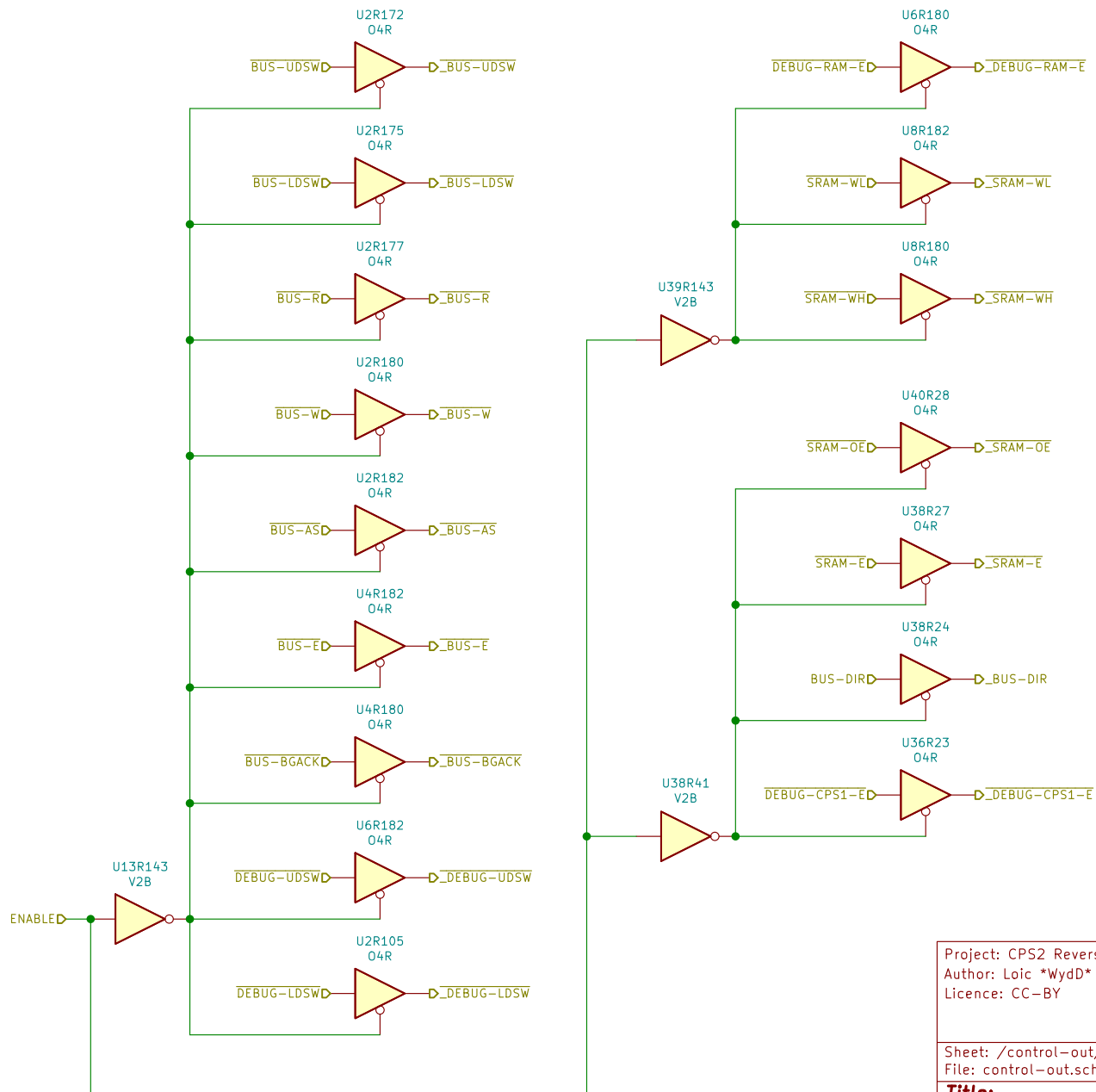

Project: CPS2 Reverse Engineering: DL-1827
 Author: Loic *WydD* Petit
 Licence: CC-BY

Sheet: /control-out/
 File: control-out.sch

Title:

Size: A4 Date: 2020-04-12
 KiCad E.D.A. eeschema 5.1.7-a382d34a887ubuntu18.04.1

Rev:
 Id: 4/20

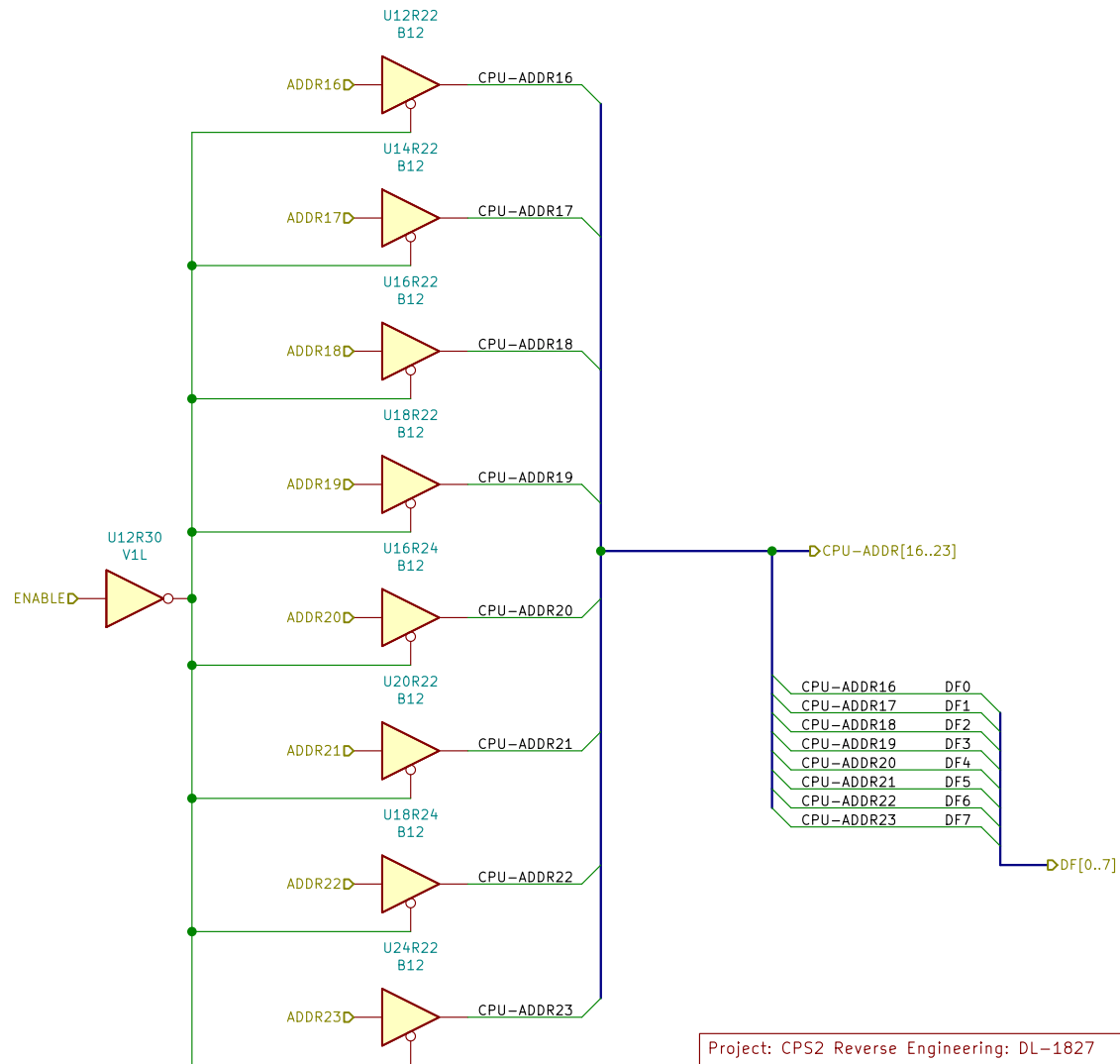

Project: CPS2 Reverse Engineering: DL-1827
 Author: Loic *Wyd* Petit
 Licence: CC-BY

Sheet: /cpu-addr/
 File: cpu-addr.sch

Title:

Size: A4 Date: 2020-04-12
 KiCad E.D.A. eeschema 5.1.7-a382d34a887ubuntu18.04.1

Rev:
 Id: 6/20

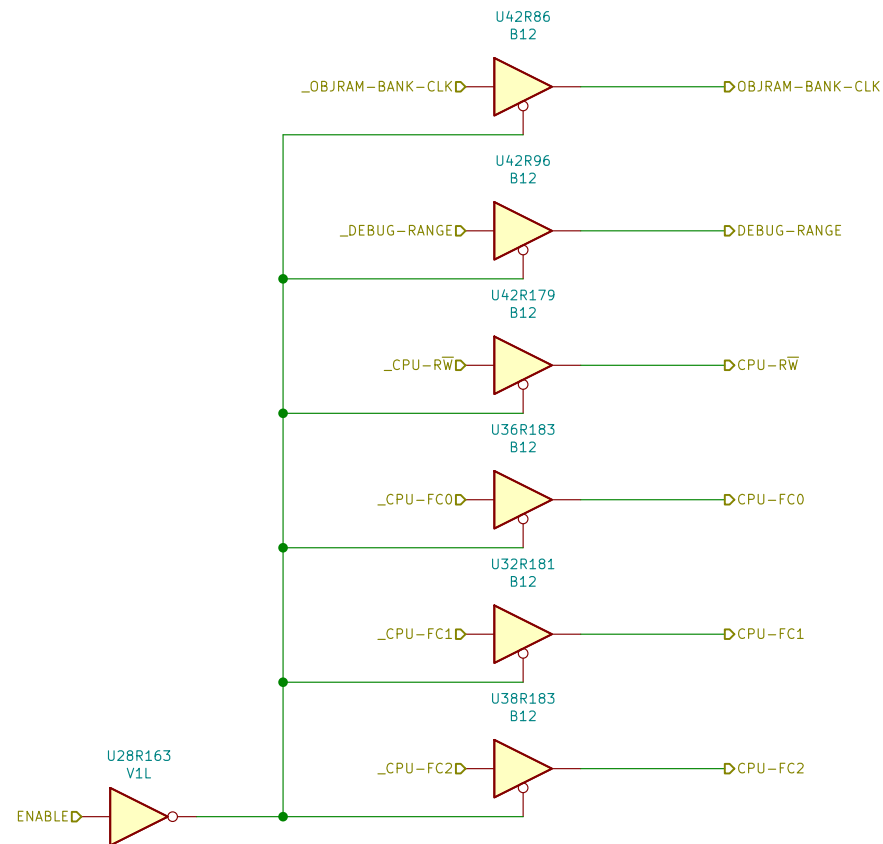

Project: CPS2 Reverse Engineering: DL-1827
 Author: Loic *WydD* Petit
 Licence: CC-BY

Sheet: /cpu-state-in/
 File: cpu-state-in.sch

Title:

Size: A4 Date: 2020-04-12
 KiCad E.D.A. eeschema 5.1.7-a382d34a887ubuntu18.04.1

Rev:
 Id: 7/20

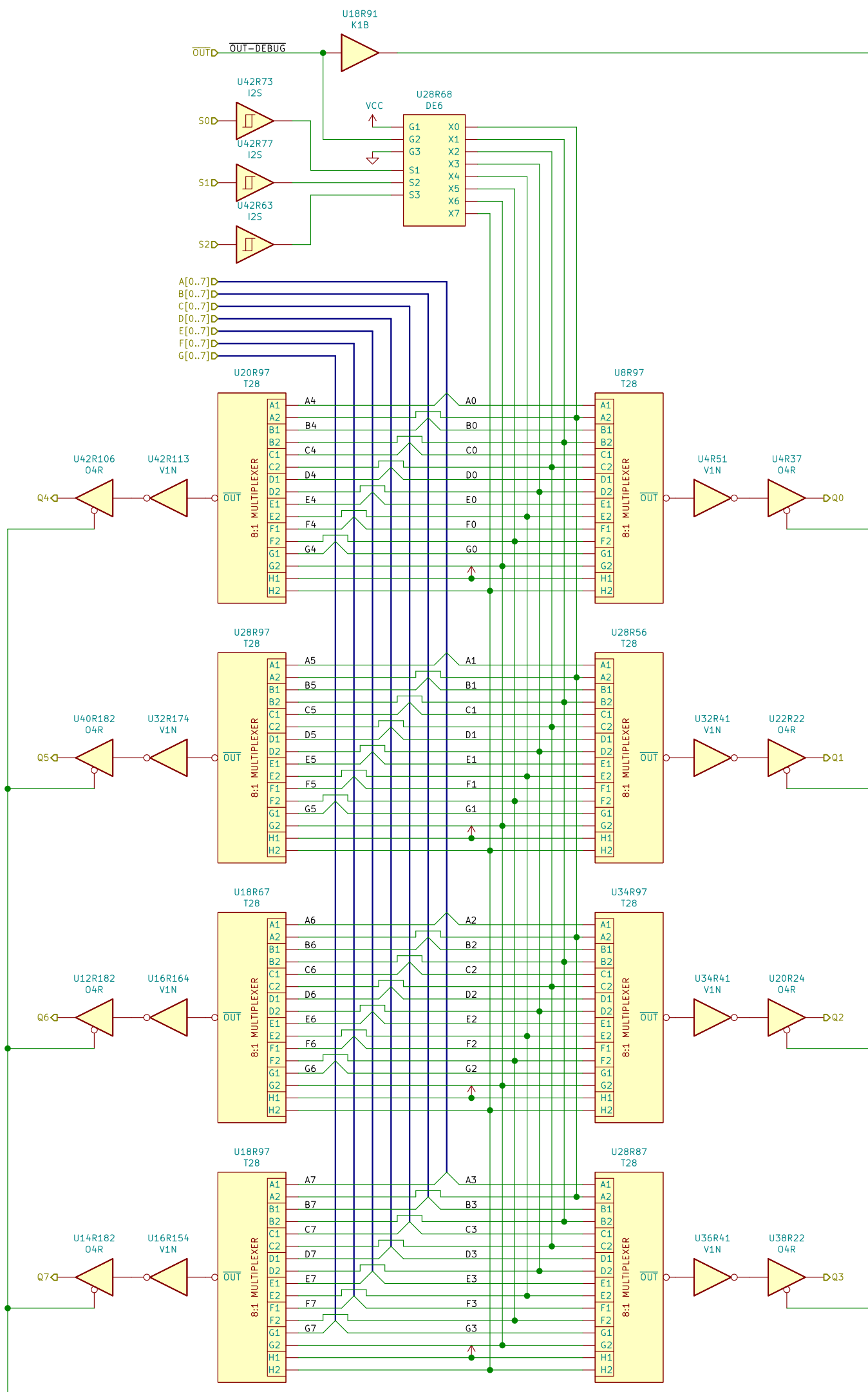

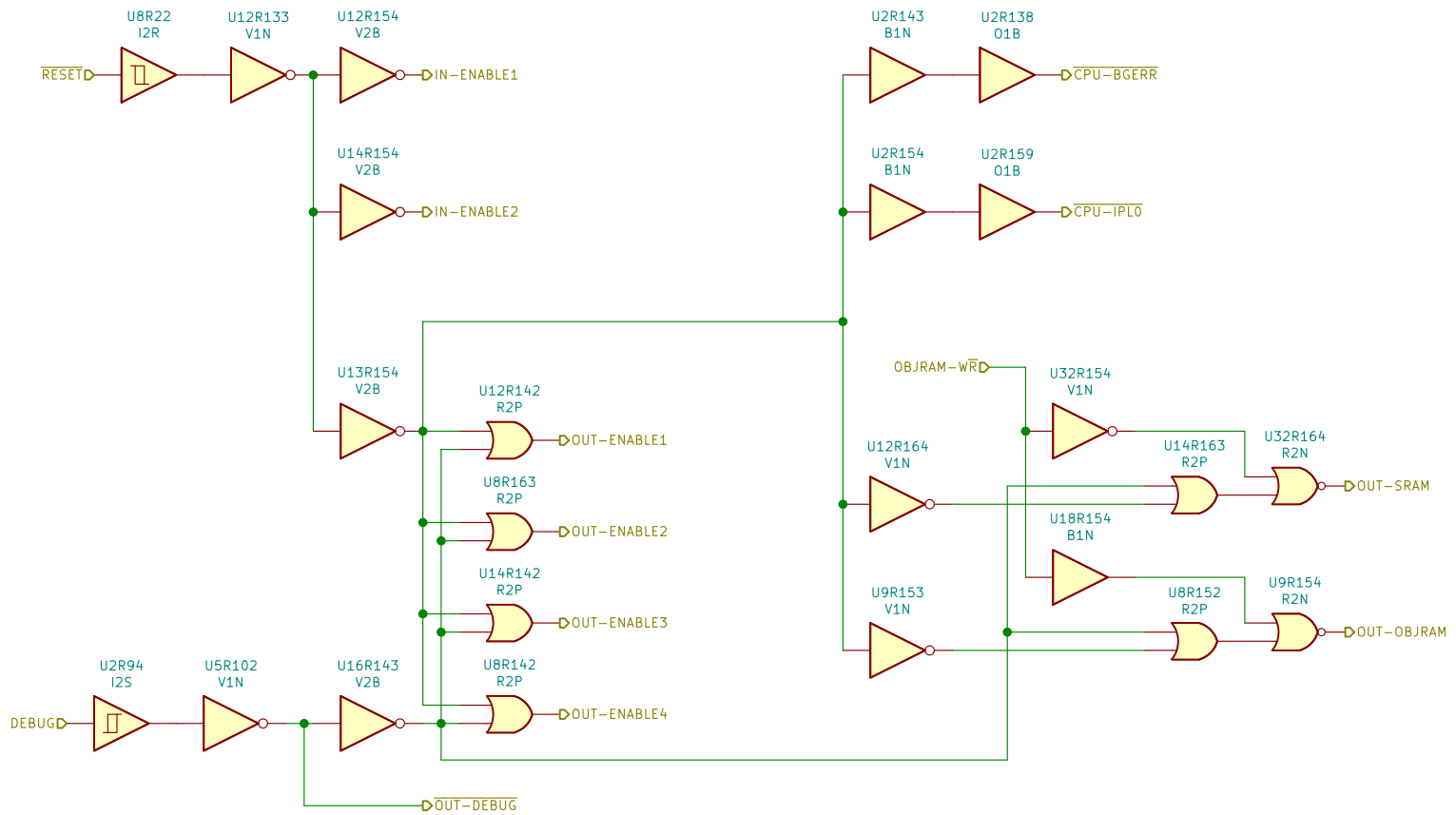

Project: CPS2 Reverse Engineering: DL-1827
 Author: Loic *WydD* Petit
 Licence: CC-BY

Sheet: /enable/
 File: enable.sch

Title:

Size: A4 Date: 2020-04-12
 KiCad E.D.A. eeschema 5.1.7-a382d34a887ubuntu18.04.1

Rev:
 Id: 9/20

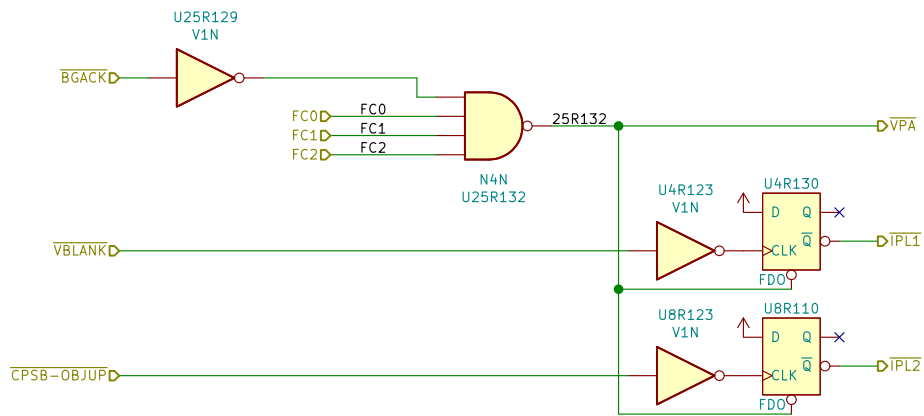

Project: CPS2 Reverse Engineering: DL-1827
 Author: Loic *WydD* Petit
 Licence: CC-BY

Sheet: /interrupt/
 File: interrupt.sch

Title:

Size: A4 Date: 2020-04-12
 KiCad E.D.A. eeschema 5.1.7-a382d34a887ubuntu18.04.1

Rev:
 Id: 10/20

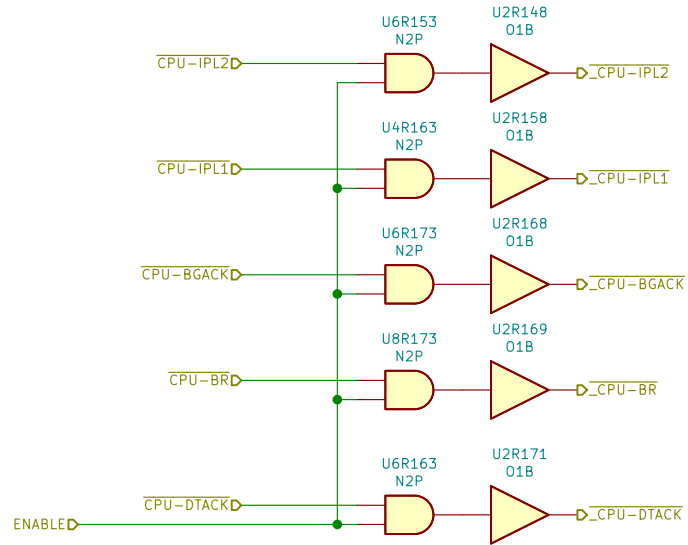

Project: CPS2 Reverse Engineering: DL-1827
 Author: Loic *WydD* Petit
 Licence: CC-BY

Sheet: /interrupt-out/
 File: interrupt-out.sch

Title:

Size: A4

Date: 2020-04-12

Rev:

KiCad E.D.A. eeschema 5.1.7-a382d34a887ubuntu18.04.1

Id: 11/20

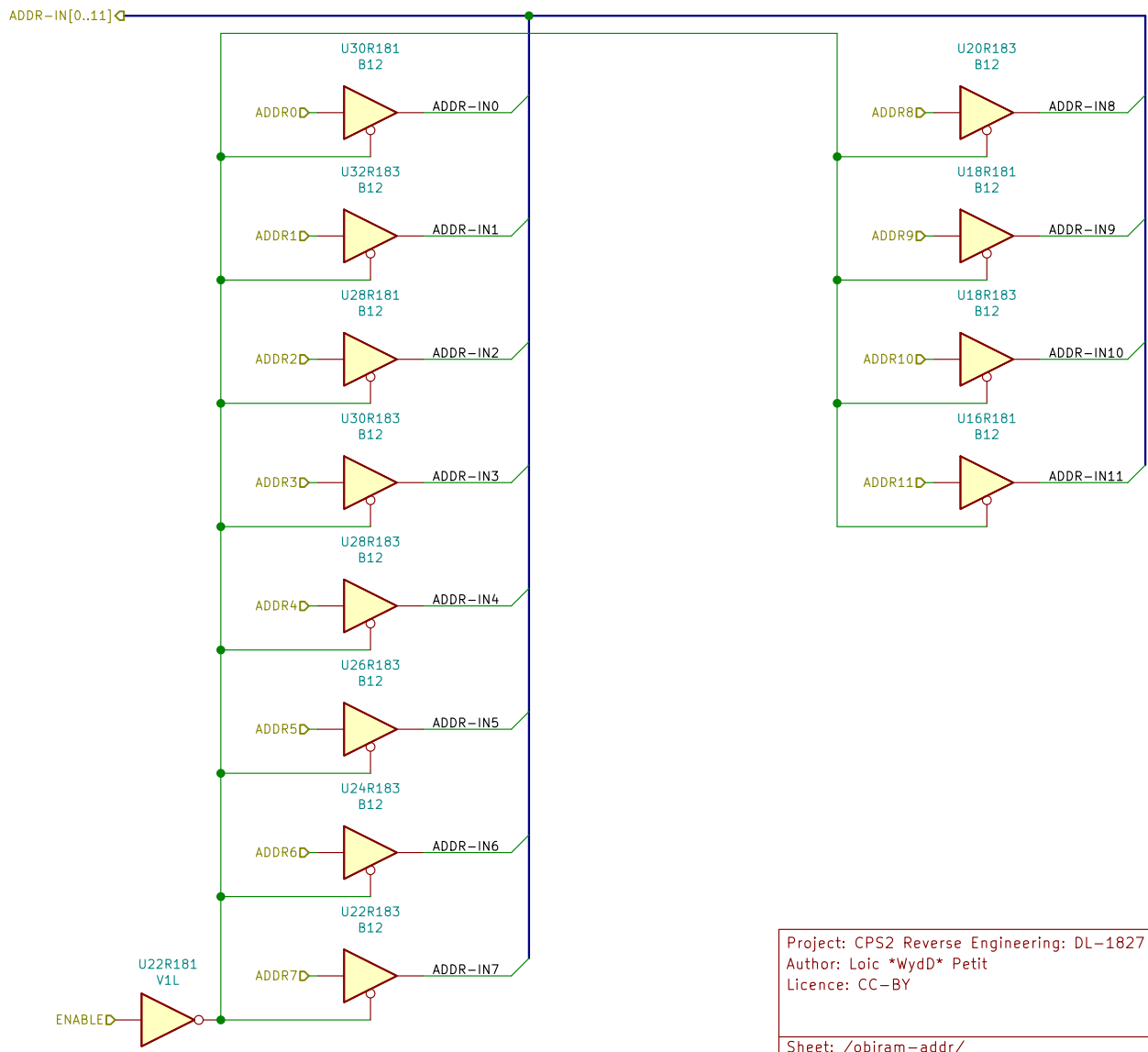

Project: CPS2 Reverse Engineering: DL-1827
 Author: Loic *Wyd* Petit
 Licence: CC-BY

Sheet: /objram-addr/
 File: objram-addr.sch

Title:		Rev:
Size: A4	Date: 2020-04-12	
KiCad E.D.A. eeschema 5.1.7-a382d34a887ubuntu18.04.1		Id: 12/20

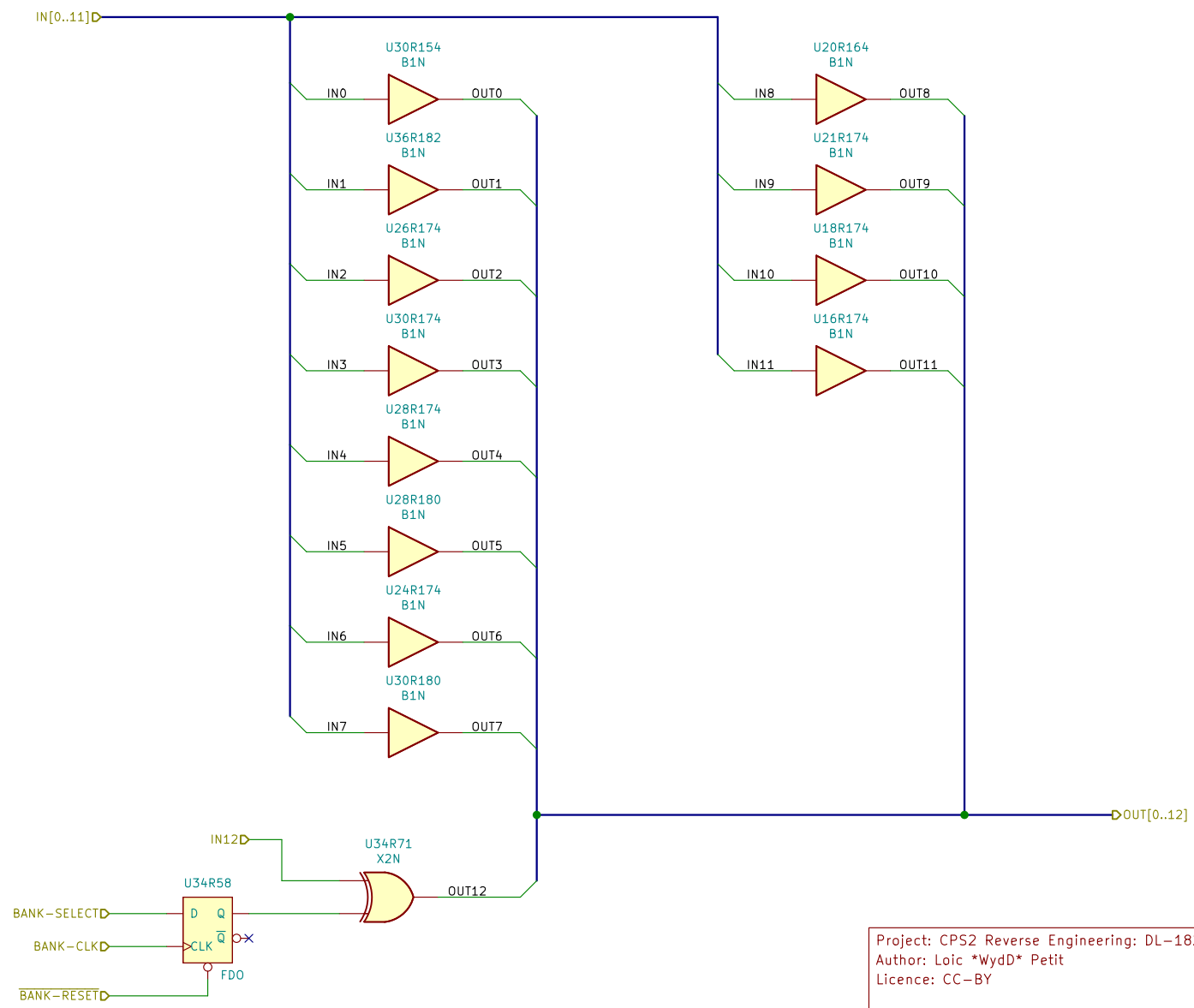

Project: CPS2 Reverse Engineering: DL-1827
 Author: Loic *WydD* Petit
 Licence: CC-BY

Sheet: /objram-addr-buffer/
 File: objram-addr-buffer.sch

Title:	
Size: A4	Date: 2020-04-12
KiCad E.D.A. eeschema 5.1.7-a382d34a887ubuntu18.04.1	
Rev: Id: 13/20	

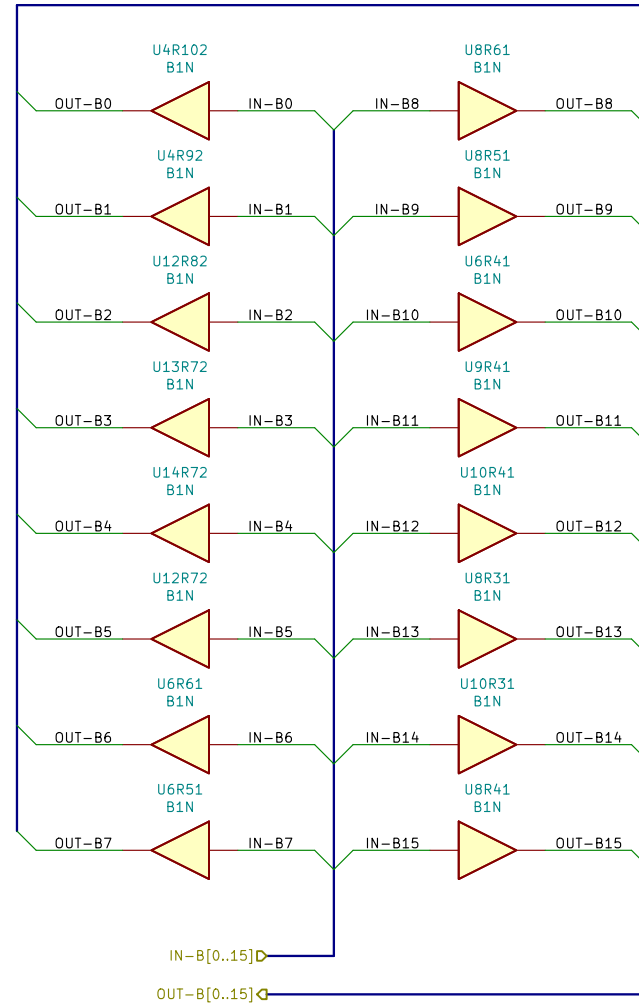
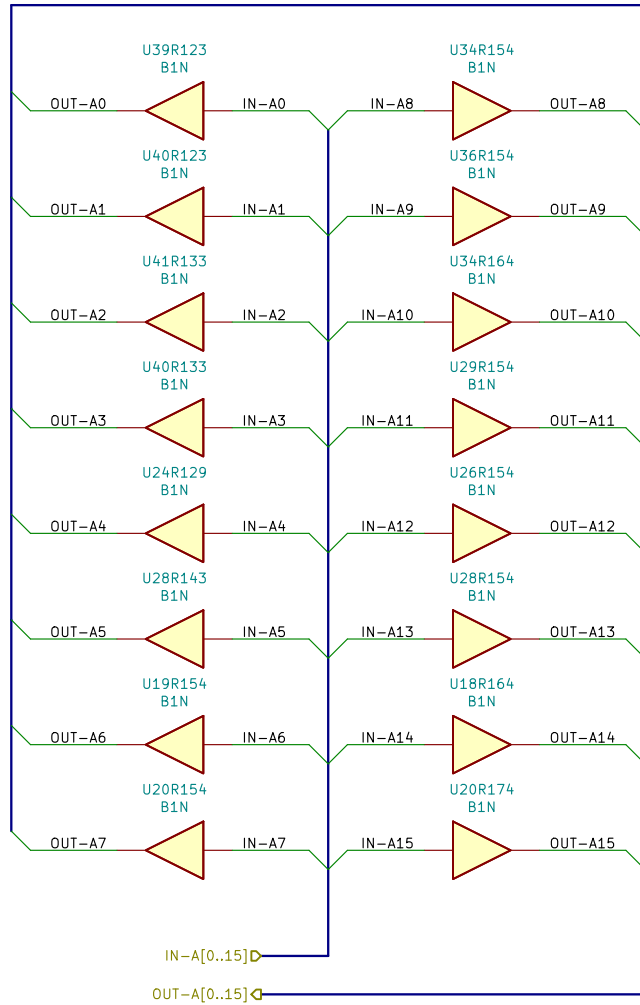

Project: CPS2 Reverse Engineering: DL-1827
 Author: Loic *Wyd* Petit
 Licence: CC-BY

Sheet: /objram-bus-buffer/
 File: objram-bus-buffer.sch

Title:

Size: A4
 KiCad E.D.A. eeschema 5.1.7-a382d34a887ubuntu18.04.1

Date: 2020-04-12

Rev:
 Id: 14/20

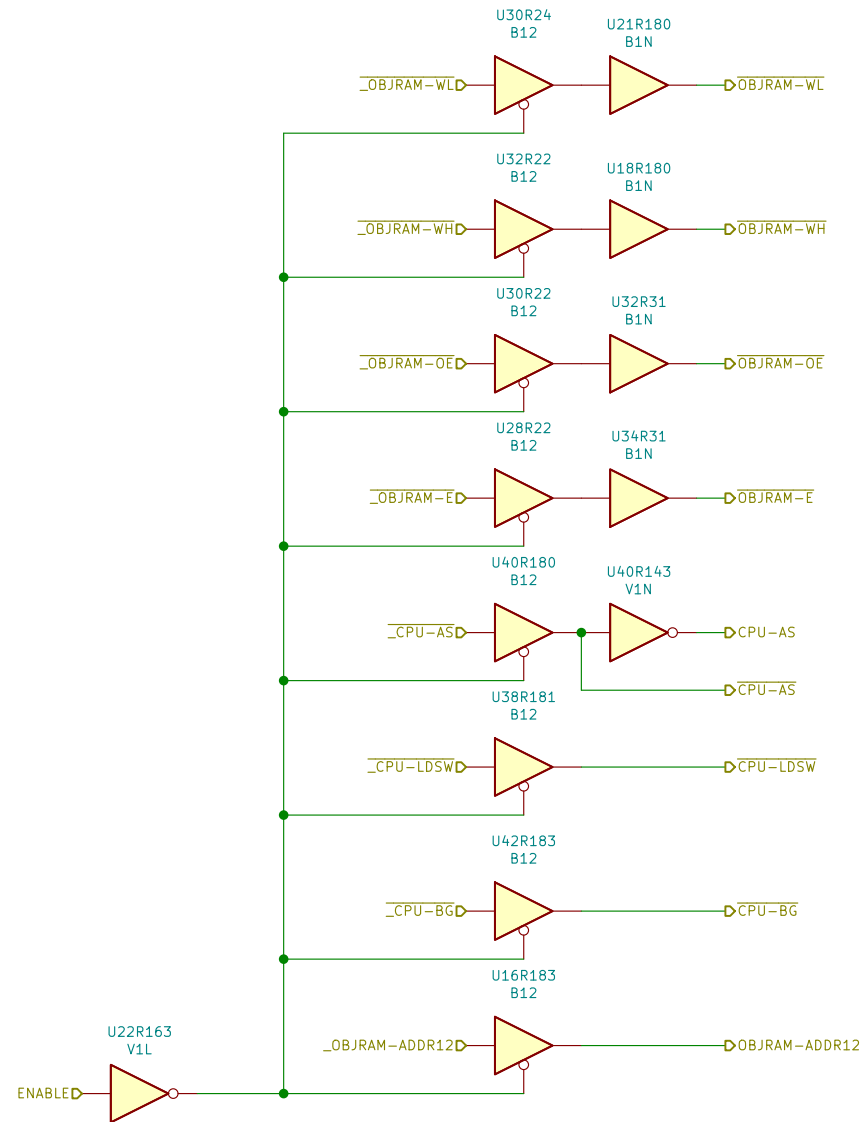

Project: CPS2 Reverse Engineering: DL-1827
 Author: Loic *WydD* Petit
 Licence: CC-BY

Sheet: /objram-control-in/
 File: objram-control-in.sch

Title:

Size: A4 Date: 2020-04-12
 KiCad E.D.A. eeschema 5.1.7-a382d34a887ubuntu18.04.1

Rev:
 Id: 15/20

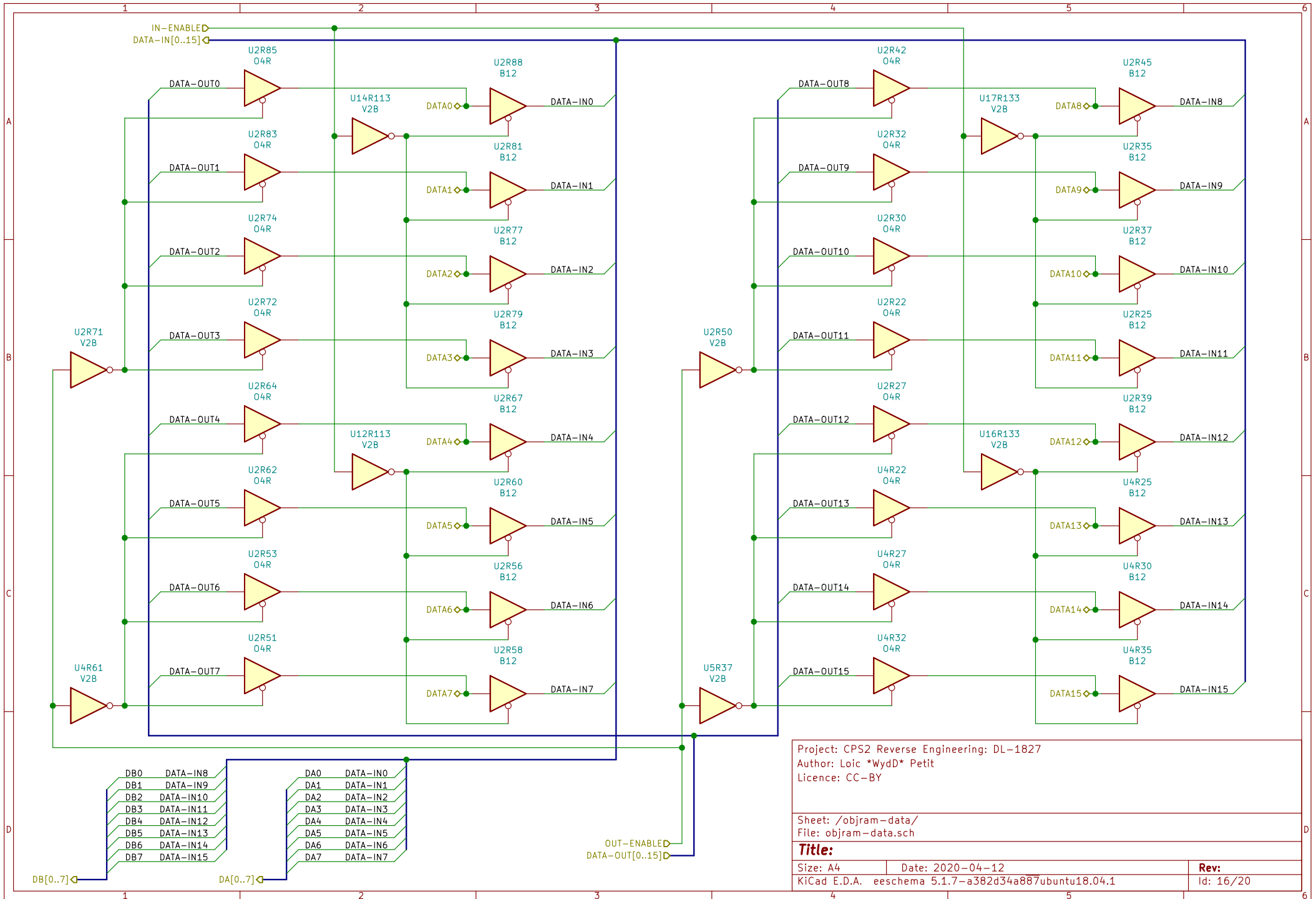

Project: CPS2 Reverse Engineering: DL-1827
 Author: Loic *WydD* Petit
 Licence: CC-BY

Sheet: /objram-data/
 File: objram-data.sch

Title:

Size: A4
 KiCad E.D.A. eeschema 5.1.7-a382d34a887ubuntu18.04.1

Date: 2020-04-12

Rev:
 Id: 16/20

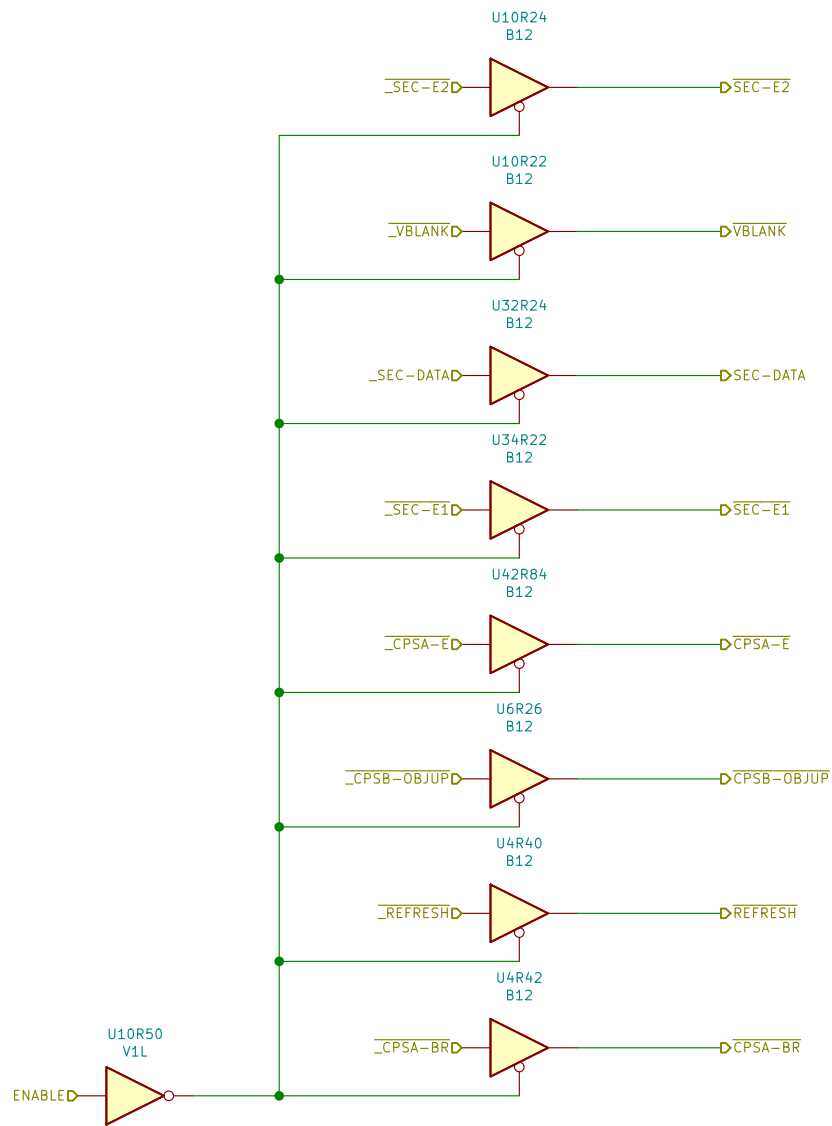

Project: CPS2 Reverse Engineering: DL-1827
 Author: Loic *WydD* Petit
 Licence: CC-BY

Sheet: /security-in/
 File: security-in.sch

Title:

Size: A4 Date: 2020-04-12
 KiCad E.D.A. eeschema 5.1.7-a382d34a887ubuntu18.04.1

Rev:
 Id: 17/20

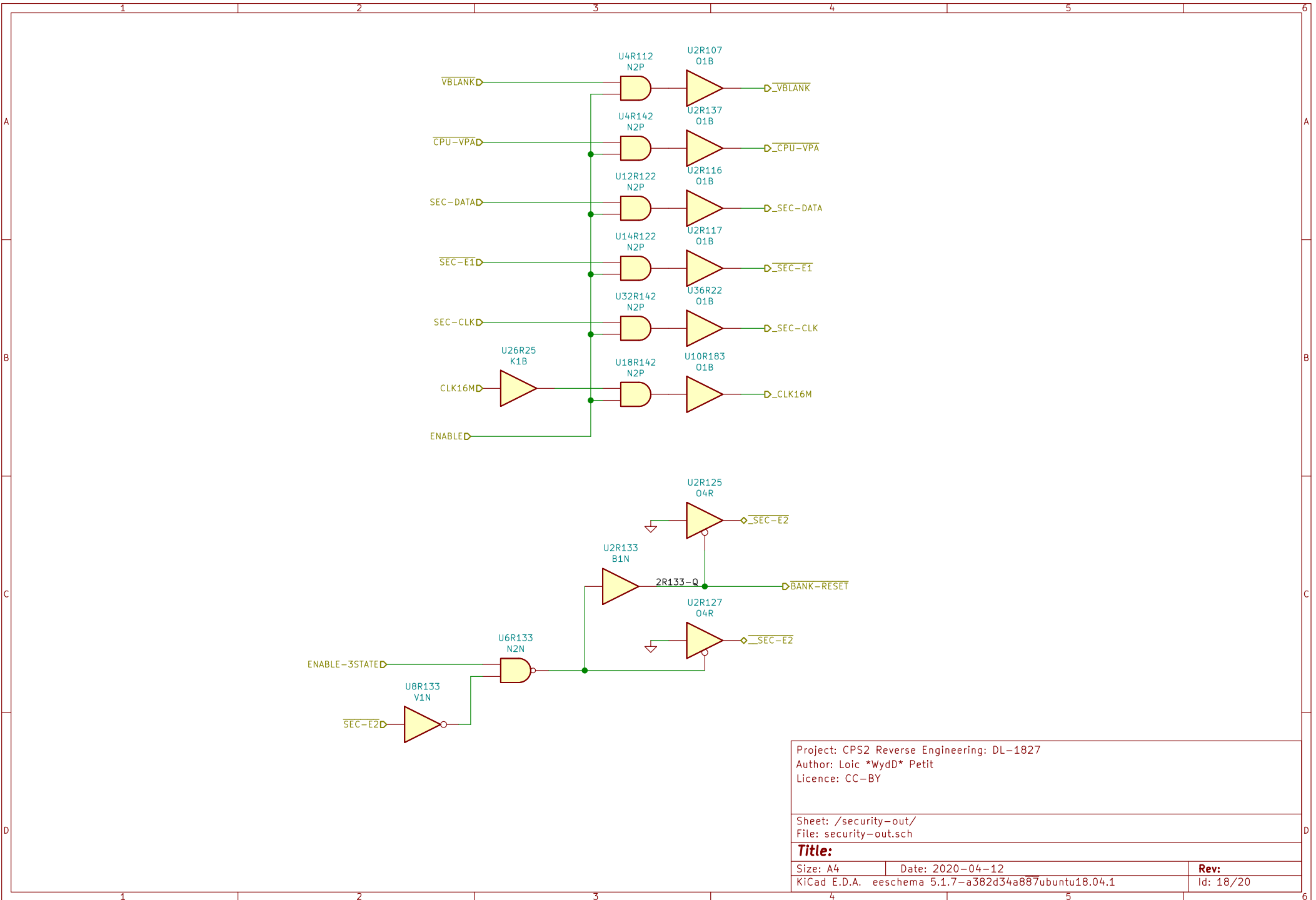

Project: CPS2 Reverse Engineering: DL-1827
 Author: Loic *WydD* Petit
 Licence: CC-BY

Sheet: /security-out/
 File: security-out.sch

Title:

Size: A4 Date: 2020-04-12
 KiCad E.D.A. eeschema 5.1.7-a382d34a887ubuntu18.04.1

Rev:
 Id: 18/20

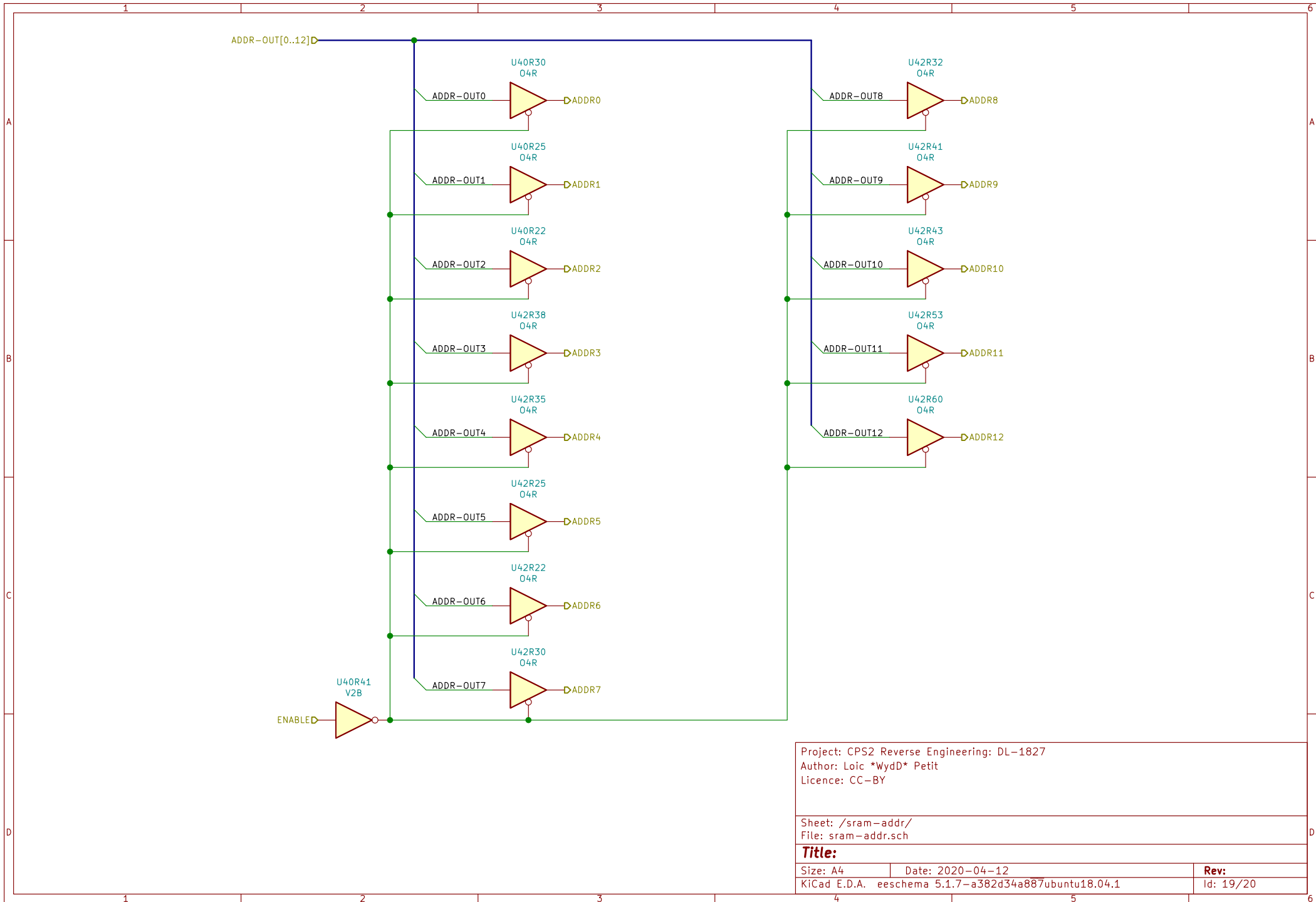

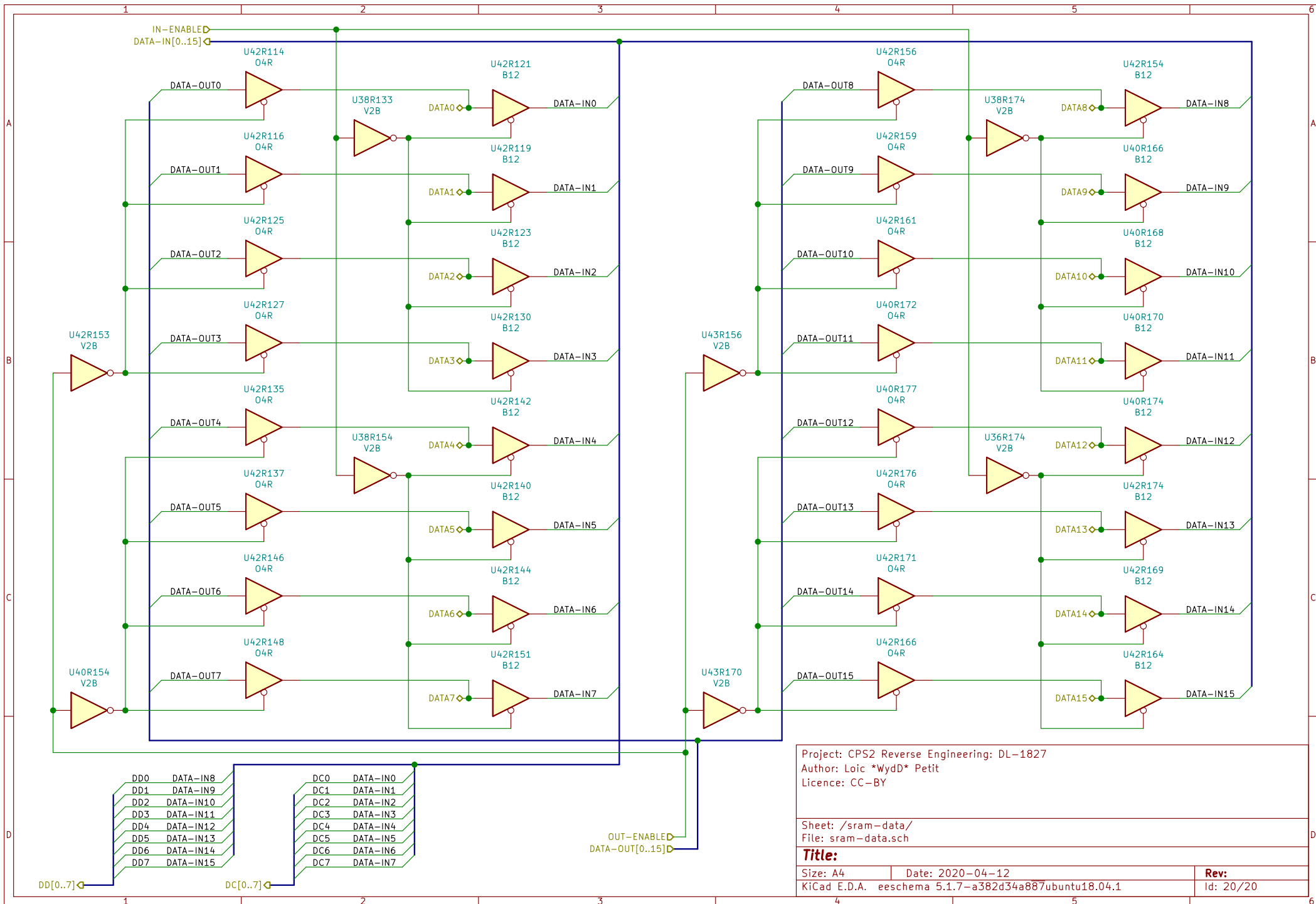

Project: CPS2 Reverse Engineering: DL-1827
 Author: Loic *Wyd* Petit
 Licence: CC-BY

Sheet: /sram-data/
 File: sram-data.sch

Title:	
Size: A4	Date: 2020-04-12
KiCad E.D.A. eschema 5.1.7-a382d34a887ubuntu18.04.1	
Rev:	
Id: 20/20	